

# Venco Products

## Potters Wheels

As at 1.5.09

### Cone drive, variable speed, Potters Wheel.



#### Venco No. 3

No.3 13" w/h \$1,005.00

#### Venco No.5

No.5 13" w/h \$1,090.00

- 330mm wheel head
- Foot pedal operated speed control (model #3)
- Foot pedal & lever operated speed control (model#5)
- Lever speed lock (model#5)
- Weight 30 kg

### Direct Drive, *wireless foot pedal*, Potters Wheel.



#### Direct Drive

Direct drive \$1,446.00

- Powerful direct drive motor
- 330mm Wheel head
- Easy clean touch switches
- Wireless Foot pedal
- Super-strong cast aluminium tray
- 550w permanent magnet motor

### High Torque Electronically controlled Potters Wheel.



#### No. 7

No. 7 \$1,865.00

- Powerful permanent magnet (DC) motor
- Exceptional torque through entire speed range
- 330mm wheel head
- Super-strong cast aluminium tray



76 mm x 300 mm Model 1

# Hand operated Clay Extruders All Stainless Steel Schools & Studios

76mm (3") x 300 mm (12")  
Barrel

\$355.85

Non-slip, notched lever  
plate

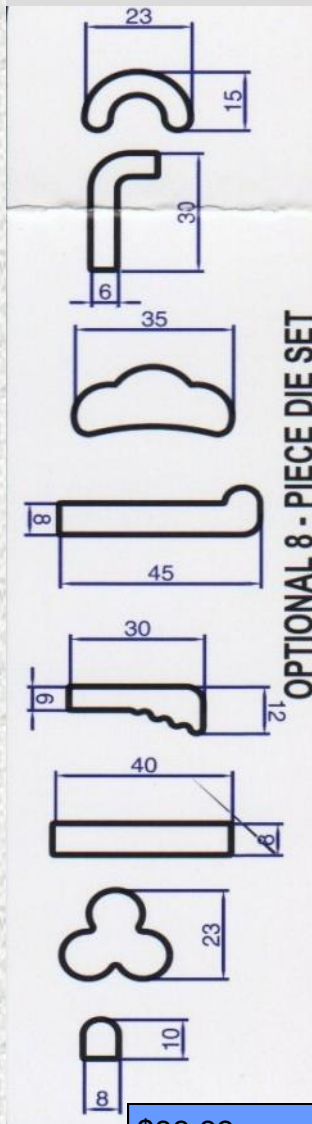

OPTIONAL 8 - PIECE DIE SET

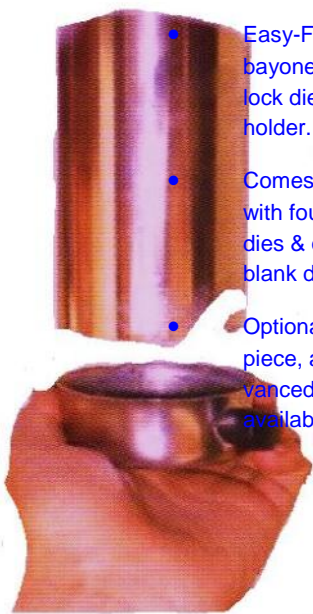

- Easy-Fit, bayonet lock die holder.
- Comes with four dies & one blank die.
- Optional, 8 piece, advanced die set available

135 mm Barrel

Plastic die Plate

Extra Long Handle

Hold up to 4 kg of clay

\$616.85

standard die set

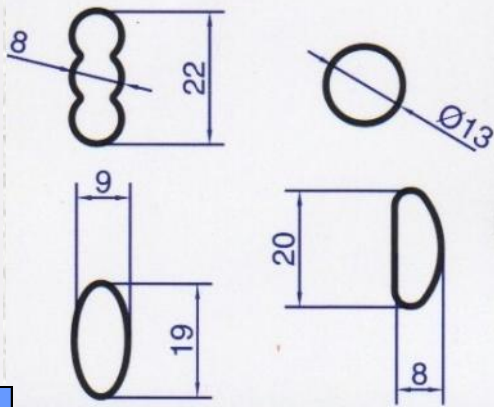

\$88.83

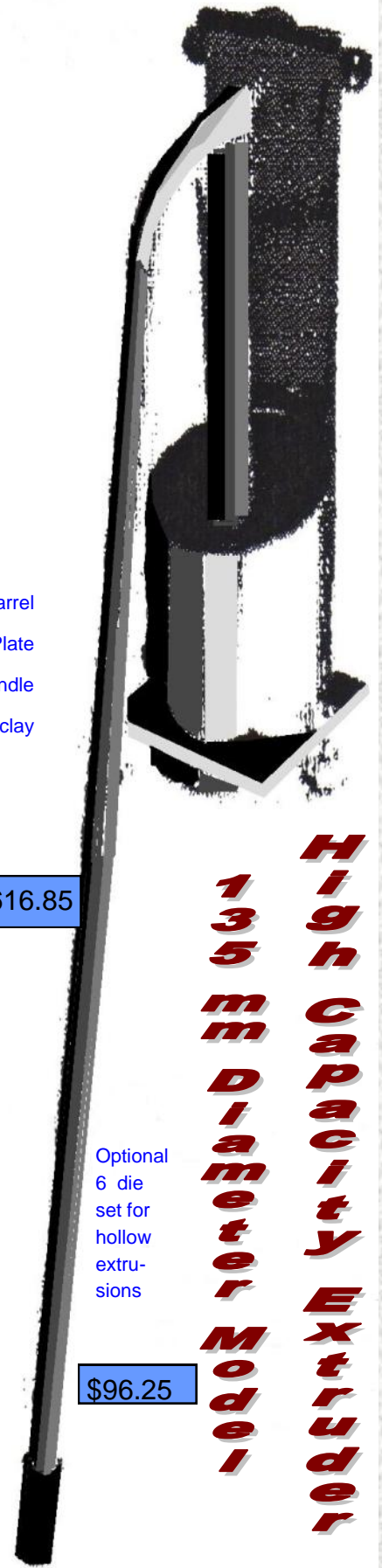

High Capacity  
135 mm Diameter  
Model Extruder

Optional  
6 die  
set for  
hollow  
extru-  
sions

\$96.25

# Slab Roller

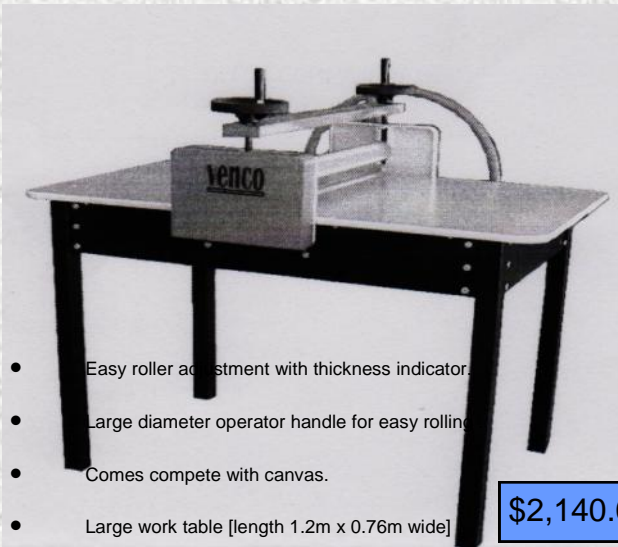

- Easy roller adjustment with thickness indicator
- Large diameter operator handle for easy rolling
- Comes complete with canvas.
- Large work table [length 1.2m x 0.76m wide]

\$2,140.05

Venco now offer a durable, economical slab roller. The slab roller will easily roll slabs up to 7.5 cm thick using the large diameter wheel. An indicator shows adjustment of the roller so that slabs may easily be duplicated at any time. The slab roller comes with durable canvas sheets.

The extremely stable is manufactured from galvanised steel and then powder coated making it very durable even in classroom conditions. The table tops are made from hand oiled marine plywood.

## Mk2 Traditional, Single Auger, Pugmills

# Pugmills



The most popular range of pugmills for professional and home potters. This well proven design [over 85000 manufactured] is distributed to more than 30 countries worldwide. Common features are double helix, stainless steel, auger driven by a high quality, industrial gear-motor. The heavy duty barrels are cast from corrosion resistant, marine-grade aluminium to ensure a long and trouble free service life. A 3 year warranty is offered.

### Venco 75mm [3"] Standard [non de-airing] Pugmill

75 mm [3"] nozzle diameter, 136mm [5 1/4"] barrel diameter.  
Hopper opening 115 x 100 mm [4 1/2 x 4"]  
180kg/hour [400lb/hr] output.  
370w [1/2 hp] fan cooled single phase motor with overload protection.



Other Venco Pugmills are also available:

- **SUPER TWIN** modular System. Large volume, twin auger mixing chamber provides effortless, self feeding. Twin meshing auger ensure efficient blending. Single heavy duty extruding auger provides exceptional thrust.
- **INDUSTRIAL** series All Stainless Steel auger with Stainless Steel barrel mixing chamber, and fittings.



# Wheel Options & Spare Parts

OPTIONS		
\$44.00	THREE PAGES for wheel head	for N°3, N°5, N°6 & N°7
\$138.60	Separate SEAT	for N°3 & N°5 only. 191
\$207.90	STAND-UP KIT	for N°3 & N°5 only. 192
\$194.70	STAND-UP KIT	for DIRECT DRIVE
\$82.50	WORK TABLES	for DIRECT DRIVE, N°3 & N°5 L&R
\$61.60	RISER BAT	for DIRECT DRIVE
\$41.80	STANDARD BAT	for DIRECT DRIVE
\$259.60	Conventional wired foot pedal	for DIRECT DRIVE
SPARE PARTS - WHEELS		
\$91.30	Drive wheel assembly (all models)	193
\$79.75	Drive Cone (all models)	194
\$40.70	Bush / Bearing kits (all models)	199
\$3.85	Resilient Polyurethane Shaft Mont's	203
\$15.95	Spring (Large)	200
\$9.35	Spring (Small)	201
\$387.20	1/4 HP MOTOR	195
\$410.30	1/2 hp MOTOR	
\$2.75	"O" RING, FIBER WASHER, or STAINLESS STEEL WASHER	697
\$38.50	SHAFT LOCKS	ALL MODELS



STAND UP KIT FOR No. 3 & 5 WHE